

# PUNCH SHEAR STRENGTH OF LUTING CEMENTS

## RESISTÊNCIA AO CISALHAMENTO DE AGENTES CIMENTANTES

**Loysiana A. CIARELLI**

**Alessandra A. ELIAS**

Trainee, Department of Operative Dentistry, Bauru School of Dentistry, USP.

**Maria Fidela de Lima NAVARRO**

Professor, Department of Operative Dentistry, Bauru School of Dentistry, USP.

**Ricardo Marins de CARVALHO**

Assistant Professor, Department of Operative Dentistry, Bauru, School of Dentistry, USP.

**L**aboratory investigation of mechanical properties of dental materials are of importance to facilitate the understanding of clinical performance and useful to explain failures. The aim of this study was to compare the shear punch strength of luting cements. Discs measuring 1.4 cm in diameter and 1.5 mm thick of Shofu type I, Advance and Fuji I glass-ionomer cements were prepared and subjected to punch testing in an universal testing machine at 7 minutes, 30 minutes and 24 hours after mixing. All materials increased significantly their punch resistance with time ( $p < 0.05$ ). At 24 hours, Shofu luting cement showed significantly higher punch resistance than Advance and Fuji I. Advance could not be tested at 7 minutes due to incomplete initial setting.

**UNITERMS:** Glass ionomer cements, strength; Glass ionomer cements, mechanical property.

## INTRODUCTION

A luting material should be selected based on several considerations including its biological compatibility and mechanical properties sufficient to resist stresses generated during occlusal adjustments of the luted crown and further occlusal function. Zinc phosphate cements and polycarboxylate cements are representatives of the most popular cements used for cementation of cast restorations. Although optimal mechanical properties have been reported for these cements<sup>5,11,12</sup>, they present limitations regarding proper adhesion to tooth structure and no protection against secondary caries at the margins of the restorations due to absence of fluoride release. The glass-ionomer cements (GIC) are now widely used materials for several purposes in clinic. The major advantages of these materials are good adhesion to mineralized dental tissues and fluoride release<sup>16</sup>. Mechanical properties have also been described as excellent as compared to several other cements<sup>5</sup>. However, no data related to the punch strength of GI luting cements is available in the literature. Punch

testing is a simple, very effective method to test the cohesive strength of solid materials in a shear mode. It has been used to test shear strength of dentin<sup>14</sup> and base materials<sup>4</sup>. One advantage of this test is that the amount of material necessary to prepare the specimens is less than that usually required to prepare specimens for conventional mechanical testing. The aim of this study was to compare the punch resistance of three commercially available GI luting cements.

## MATERIALS AND METHODS

All the materials were prepared according to the manufacturer's instructions and mixed on a glass slab at room temperature (23° C) and 50% relative humidity. Powder/liquid ratios of 1.5:1.0, 1.8:1.0 and 0.2:0.1 wt/wt were used for Shofu I (Shofu Inc., Osaka, Japan), Fuji I (GC Inc., Tokyo, Japan) and Advance (Caulk Dentsply, Milford, DE, USA), respectively. Immediately after mixing, the materials were inserted into circular metal matrices and sandwiched between two glass slabs separated

from the cements by a thin cellophane sheet. The circular metal matrices had an internal diameter of 1.4 cm and thickness of 1.5 mm. The glass slabs were secured with clamps and the materials allowed to set for 15 minutes before being disassembled from the glass slabs, immersed in distilled water and kept in an oven at 37° C until tested. The specimens, in a number of six per group, were tested included in the circular matrices. The samples tested at 7 minutes were allowed to set for 5 minutes and immediately assembled in the universal testing machine for testing. Immediately after removal of the glass slabs, the specimens were gently trimmed with a blade to remove any excess. The thickness of each specimen was measured with a digital caliper and recorded. The materials were tested at 7 minutes, 30 minutes and 24 hours after mixing in a Kratos testing machine at 0.5 mm/minute.

Figure 1 illustrates the diagram of the testing method employed in this study<sup>4</sup>. The punch strength was calculated by the following formula:

$$\text{Punch strength} = \frac{\text{Load (Kg)}}{\pi \cdot d \cdot h} = \text{Kg/cm}^2$$

where:

$$\pi = 3.1416$$

d = diameter of the vertical indenter from the testing device

h = thickness of the sectioned area of the specimen

The data were submitted to two-factor ANOVA (luting material and time) and Student-Newman-Keuls test to reveal individual differences between materials and time. Statistical significance was set as  $p < 0.05$ .

## RESULTS

The data obtained for the three materials in each

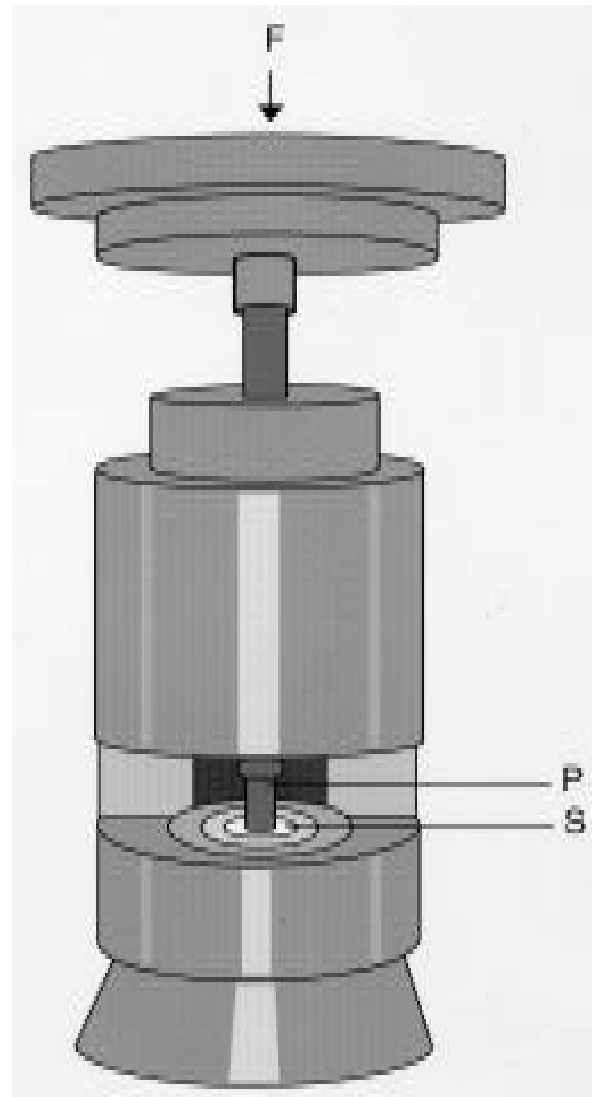

**FIGURE 1** - Punch testing device. F = Stage for axial force application; P = punch indenter; S = specimen included in the circular matrix

time period are summarized in Table 1. All the materials tested presented a significant increase in punch strength with time. Advance material could not be tested at 7 minutes because the consistency was still not hard enough to permit testing. At 7

**TABLE 1**- Shear punch strengths [Kg/cm<sup>2</sup>, mean ± s.d. (n)] for glass ionomer cements after 7 minutes, 30 minutes and 24 hours

Material	7 minutes*	30 minutes*	24 hours
Shofu	42.4 ± 5.7 (6)	91.1 ± 8.2 (6)	274.8 ± 17.0 (6)
Advance	—	147.2 ± 15.4 (6)	207.8 ± 10.0 (6)
Fuji I	24.1 ± 3.7 (6)	119.4 ± 3.4 (6)	185.3 ± 37.8 (6)

\* All values increased significantly with time. Data connected by vertical line are not statistically different ( $p > 0.05$ ).

minutes, Shofu showed higher punch strength than Fuji I ( $p < 0.05$ ). At 30 minutes, Advance was the strongest material followed by Fuji I and Shofu ( $p < 0.05$ ). At 24 hours, Shofu achieved the highest strength which was statistically different from the other two materials ( $p < 0.05$ ). Advance and Fuji I were not different at the same testing period ( $p > 0.05$ ).

## DISCUSSION

Generally, laboratory experiments are designed to simulate the complex environment of the mouth. The rationale for this study relies on the fact that luted crowns may be submitted to occlusal loads as soon as the patient is dismissed. Occlusal loads have been described in the literature as being variable and ranging from 2 to 40 Kg<sup>2,15</sup>. It is difficult to determine the stress developed at the luting cement during the application of occlusal loads on the crowns. That would probably be influenced by the type of preparation and the material used to make the crown (i.e. metal, porcelain, etc.)<sup>2</sup>. Although the stresses experienced by a luting cement under a crown are highly complex, a failure at the cement line will certainly be determined by the cohesive strength of the cement.

Mondelli et al.<sup>6</sup> reported that zinc phosphate cements (ZPC), the most popular luting agent, resulted in approximately 100 Kg/cm<sup>2</sup> of punch strength at 7 minutes which increased to a maximum of 138 Kg/cm<sup>2</sup> after 24 hours, using the same method employed in this study. Our data suggests that the GIC used in this study are much weaker than ZPC at early periods of setting. However, at 30 minutes, the materials tested here showed similar values as those encountered by Mondelli et al.<sup>6</sup> (c.a. 137 Kg/cm<sup>2</sup>). Moreover, after 24 hours, while the resistance of ZPC did not increase any further<sup>6</sup>, GICs showed a significant increase of the punch resistance. This is probably due to the setting process of conventional GICs which is known to occur within a period of 24 hours<sup>16</sup>. Light-activated GICs would probably result in much higher strength at early periods as previously shown<sup>4</sup>. However, unless they present a dual-cure mode of setting, they are not suitable for luting purpose. The increase in the mechanical properties of conventional GICs with time was also a general observation of other authors<sup>5</sup>. Indeed, the gradual increase in the mechanical properties of cements are highly related to their respective setting mechanism. Considering this approach, the

results offered by this method are well correlated with other conventional testing methods.

The low strength of GICs at early periods of setting could be a problem during the eventual need of occlusal adjustments after crown cementation because these procedures could cause early fragmentation of the thin layer of luting cements. Although this is a common clinical thought, no evidences are found in the literature to prove it. Conversely, the low initial modulus of the setting material could be desirable to better resist such vibrational stresses during occlusal adjustments. The critical drawback of GICs used for crown cementation was the initial sensitivity to moisture observed with earlier materials<sup>7</sup>. This does not seem to be a problem with the more recently, fast-setting developed materials<sup>7</sup>. The excess left at the margins during setting of the crown appears to be enough to prevent early moisture contamination of the cement layer<sup>7</sup>. Additional advantages of using GICs as luting materials are less microleakage<sup>8</sup>, fluoride release<sup>10</sup>, prevention of secondary caries at the margins of the preparation<sup>13</sup> and better retention of the crowns<sup>1</sup>.

Advance GIC could not be tested at 7 minutes due to absence of initial setting which caused the material to be too soft to create any resistant to the applied load. However, it achieved the highest strength at 30 minutes when compared to the other materials. This might be explained by the slower rate of setting at earlier periods presented by this particular material. However, this event might have been an isolated fact in this study since we did not find any similar report in the literature. Most of the studies related to the mechanical properties of cements present data obtained only 24 hours after setting. Although the strength achieved by Advance at 30 minutes is consistent, the poor initial strength may cause significant problems during crown cementation with regard to the sensitivity of this cement to moisture while it does not set. In this matter, fast-setting cements are more desirable and appropriate for this clinical procedure.

The GICs used in this study showed punch resistance that was similar or even superior to other general luting cements tested by the same methodology<sup>9,11,12</sup>. This mechanical property seems to be well correlated to other more commonly evaluated properties<sup>3,5,9</sup>. Considering other advantageous properties of GICs as compared to ZPC and polycarboxylate cements, they can be regarded as a good option for luting crowns in clinics.

In summary, the punch shear values increased with time for all the three materials tested. This is related to the setting behavior of the cements.

## RESUMO

Estudos laboratoriais são importantes para facilitar o entendimento do comportamento clínico dos materiais e úteis para explicar as falhas. O objetivo deste estudo foi comparar a resistência coesiva de agentes cimentantes submetidos a tensões de cisalhamento (punch shear test). Discos medindo 1,4 cm de diâmetro por 1,5 mm de espessura foram preparados dos cimentos de ionômero de vidro Shofu (tipo I), Advance e Fuji (tipo I) e testados em máquina universal de testes nos períodos de 7 minutos, 30 minutos e 24 horas após a mistura. Todos materiais apresentaram um significativo aumento de resistência entre os períodos ( $p < 0,05$ ). No período de 24 horas, o cimento Shofu apresentou uma resistência significativamente maior do que os cimentos Advance e Fuji. O cimento Advance não pode ser testado no período de 7 minutos devido a sua consistência inicial não permitir o teste.

**UNITERMOS:** Cimentos de ionômero de vidro, resistência; Cimentos de ionômero de vidro, propriedade mecânica.

## REFERENCES

- 1- ANDRADA, R. C. **Resistência à remoção por tração e infiltração marginal de coroas totais fundidas cimentadas em dentes naturais reconstruídos com ionômero de vidro.** Bauru, 1992. 106p. Tese (Doutorado) - Faculdade de Odontologia de Bauru, Universidade de São Paulo.
- 2- BLACK, S.; AMOORE, J.N. Measurements of forces applied during the clinical cementation of dental crowns. **Physiol. Meas.**, v.14, n.3, p. 387-92, Aug. 1993.
- 3- BURGESS, J.O. et al. A comparative study of three glass ionomer base materials. **Amer. J. Dent.**, v.6, n.3, p. 137-41, June 1993.
- 4- CARVALHO, R.M.; DEL'HOYO, R.B.; SUGA, R.S. Strength of base materials. **Amer. J. Dent.**, v.8, n. 3, p. 128-30, June 1995.
- 5- CATTANI-LORENTE, M.A.; GODIN, C.; MEYER, J.M. Mechanical behavior of glass-ionomer cements affected by long-term storage in water. **Dent. Mater.**, v.10, n.1, p. 37-44, Jan.1994.
- 6- MONDELLI, J. et al. Resistência ao cisalhamento por punção, compressão e tração diametral de cimentos utilizados como base protetora de restaurações. **Rev. Fac. Odont. Bauru**, v.2, n.1, p.1-6, 1994.
- 7- MOUNT, G. J. **Glass ionomer cements: a clinician guide.** London; Martin Dunitz, 1990.
- 8- NAVARRO, M.F. de L. et al. Infiltração marginal em coroas totais cimentadas com fosfato de zinco, ionômero de vidro e poliacarboxilato. Estudo in vitro e in vivo. **Estomat. Cult.**, v. 13, n. 1, p. 9-13, jan./mar. 1983.
- 9- PALMA, R.G. et al. Resistência à compressão e à tração diametral de cimento de ionômero de vidro convencional e reforçado com metal. **Rev. Odont. Univ. São Paulo**, v. 8, n. 4, p. 233-8, out./dez. 1994.
- 10- PASCOTTO, R.C. et al. Fluoride release pattern from glass-ionomer luting cements. **J. dent. Res.**, v. 75, n. 3, p. 170, 1996. Special issue. /Abstract 1220/
- 11- SANTOS, J.F.F.; STEAGALL, L.; DEL BIANCO, A. Strength of cement bases. **Oper. Dent.**, v.3, n. 4, p. 122-7, Autumn 1978.
- 12 - SANTOS, J.F.F.; STEAGALL, L.; SILVEIRA, J. I. Punch shear strength of polycarboxylate cements. **J. prosth. Dent.**, v. 39, n. 4, p.420-3, Apr. 1978.
- 13- SERRA, M.C.; CURY, J. A. The in vitro effect of glass-ionomer cement restoration on enamel subjected to a demineralization and remineralization model. **Quintessence Int.**, v. 23, n. 2, p.143-7, Feb. 1992.
- 14- SMITH, D.C.; COOPER, W.E. The determination of shear strength. A method using a micropunch apparatus. **Brit. J. Dent.**, v. 130, n. 8, p. 333-7, Apr. 1971.
- 15- TAMAKI, T. ATM. **Noções de interesse protético.** 2. ed. São Paulo, Sarvier, 1981. p.11.
- 16- WILSON, A. D.; MCLEAN, J.W. **Glass-ionomer cement.** Chicago, Quintessence, 1988.

Corresponding author:  
Dr. Ricardo M. Carvalho  
FOB USP, Dentística  
Al. Otávio P. Brisola, 9-75  
Bauru, SP, 17012-901  
Fax: ++ 55 14 235 8321  
e-mail:rickcarvalho@hotmail.com